

DIMENSIONS			
WINCH MODEL	A	*B	C
RPH-10000S (STD. DRUM)	27.48 698,0	12.25 311,2	9.75 247,7
RPH-10000Y ("Y" DRUM)	24.23 615,4	9.00 228,6	6.50 165,1

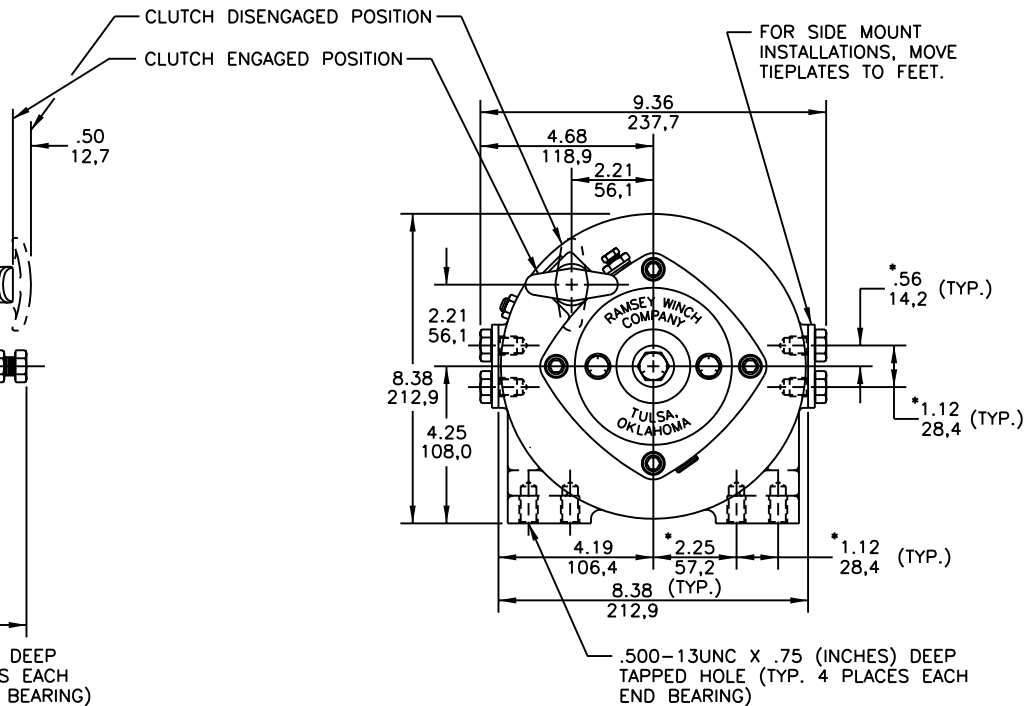
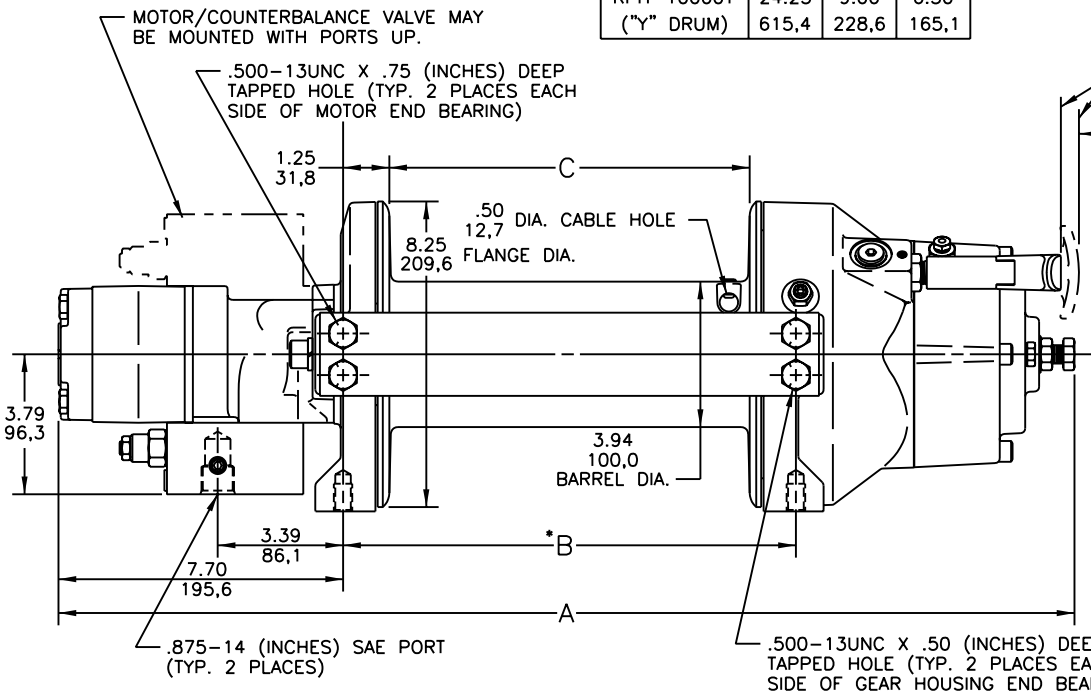

DIMENSIONS SHOWN ARE INCHES OVER MILLIMETERS
WINCH MOUNTING CAPSCREWS MUST MEET OR EXCEED SAE GRADE 5 SPECIFICATION

*NOTE: THESE HOLE LOCATIONS MUST BE HELD WITHIN $\pm .03"$ (0.8 MM) OF TRUE POSITION. RECOMMENDED MOUNTING HOLE DIAMETER IS $.53"$ (13.5 MM).