

DIM. LETTER	RPH-10,000-S ("STD." DRUM)	RPH-10,000-Y ("Y" DRUM)
A	9.75 247,6	6.50 165,1
* B	12.25 311,1	9.00 228,6
C	27.48 698,0	24.23 615,4

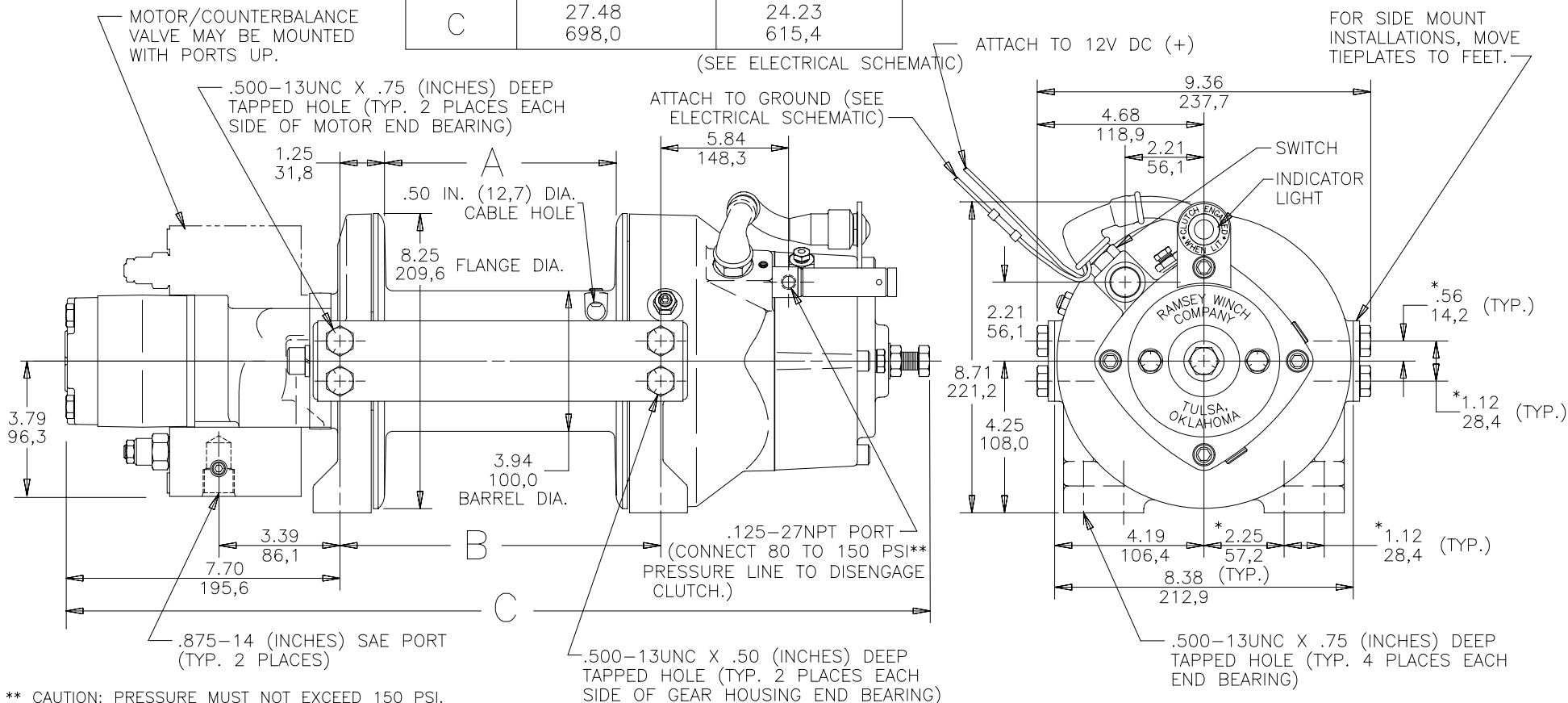

DIMENSIONS SHOWN ARE INCHES OVER MILLIMETERS
WINCH MOUNTING CAPSCREWS MUST MEET OR EXCEED SAE GRADE 5 SPECIFICATION

*NOTE: THESE HOLE LOCATIONS MUST BE HELD WITHIN ±.03" (0.8 MM) OF TRUE POSITION. RECOMMENDED MOUNTING HOLE DIAMETER IS .53" (13.5 MM).

